

Post Processing Accessories



E V O K E D
3D PRINTING SOLUTIONS

3D AutoBLAST – Automated Basket Blaster

Maximise Productivity & Reduce Manual Labour

- ✓ Automatic Mode – Two Stage:
 - ✓ Dual head hands free auto bead blasting for small to medium parts
 - ✓ Operator adjustable duration and pressure settings
 - ✓ Variable speed, lined 500mm x 300mm basket for bulk parts (parts must be suitable for tumbling action)
 - ✓ Final stage air blower for dust free finish
- ✓ Manual Mode:
 - ✓ Foot pedal activated blast action
 - ✓ Fixed or handheld blast gun operation
 - ✓ Manual trigger air blower
- ✓ Supports various industry standard blast and peening media
- ✓ High volume auto reverse pulse dust collector
- ✓ 20L dust collection drum
- ✓ Quick change media hopper
- ✓ Safety interlocks
- ✓ Complies with Australian Electrical Standards



Indicative image actual product configuration may vary slightly



Post Processing Accessories



E V O K E D
3D PRINTING SOLUTIONS

3D AutoBLAST - Automated Basket Blaster

Site Requirements

- ✓ 50 CFM @ 100 psi - Dry Air
- ✓ 2 x 240 Volt, 3 Pin 10 Amp Supply
- ✓ Cabinet weight 300 kgs
- ✓ Dust collector 3m included hose length
- ✓ Cabinet earth point provided
- ✓ Cabinet height: 1,964mm
- ✓ Dust collector height: 2,350mm
 - ✓ 200mm overhead clearance reqd
- ✓ Forklift unload required
- ✓ Hearing protection recommended during operation
- ✓ User installable

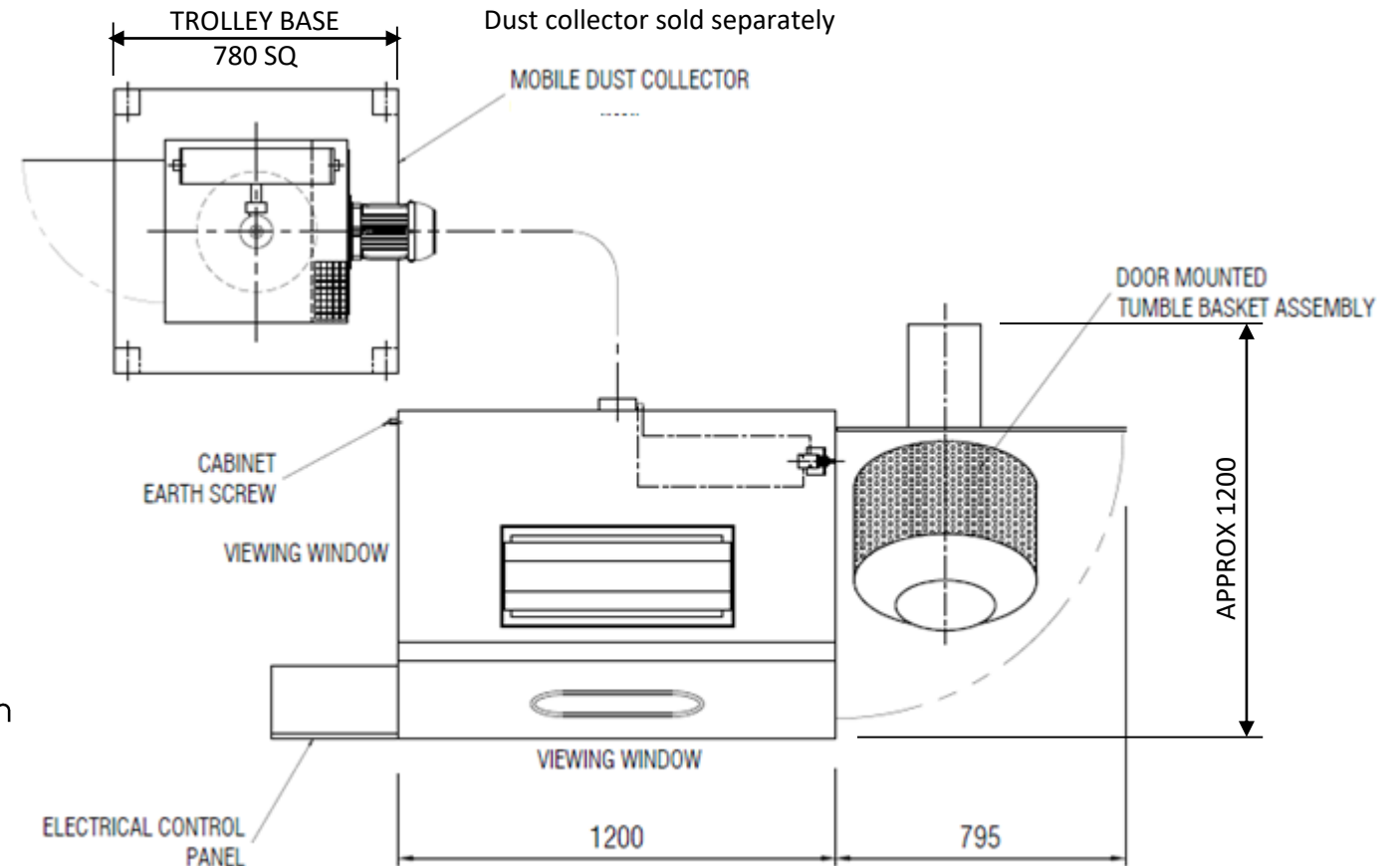

PLAN VIEW

